

1. PRECAUTION

For the correct use of this product, read through this manual before use. Please keep this manual carefully after use. This instrument has been thoroughly tested at the factory before shipment. When you receive it, visually inspect it for damage and check the accessories.

2. CHECKING PRODUCT SPECIFICATIONS AND THE CONTENTS OF PACKING

(1) Model Number and Specification Check

Check that the model number and specifications shown on the nameplate attached on the side of the product are as ordered.

(2) Contents of the Packing

Check that packing contains the following items:

- CCQ8 main unit × 1
- Instruction Manual × 1

3. GENERAL

This plug-in isolator, which belongs to the SMPSC series of signal conditioners, receives DC current or voltage signals and converts them to pairs of isolated DC voltage or current signals.

• Output-2 signal is selectable from a DC voltage signal, DC current signal, communication function (RS-485), and alarm output (two relay contacts).

4. MOUNTING METHODS

4.1 Wall Mounting

Loosen the main unit-fixing screw isolator to disconnect the main unit from the socket. Next, anchor the socket onto the wall with screws. Then, plug the main unit into the socket and secure the main unit with the main unit-fixing screw.

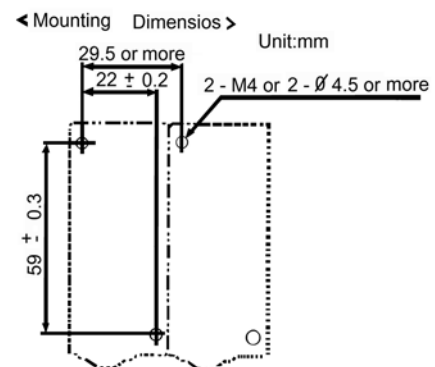
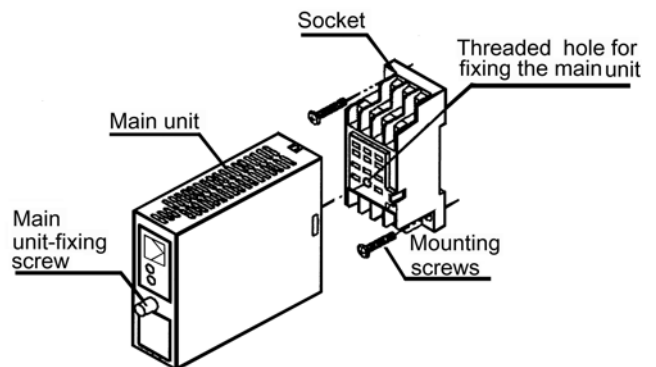

4.2 DIN Rail Mounting

Locate the isolator so that DIN rail fits into the upper part of the DIN-rail groove at the rear of the socket, and fasten the socket using the slide lock at lower part of the socket.

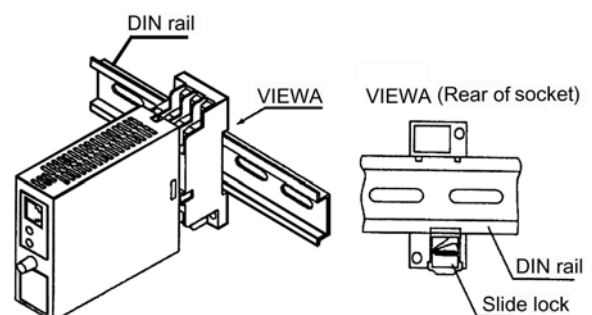

4.3 In Case of Top-Bottom Close Mounting

Transmitter should be mounted horizontally with its top and bottom slits being vertical. The top and bottom slits should not be covered. The area for wiring is required above and below the transmitter (the area with slant lines).

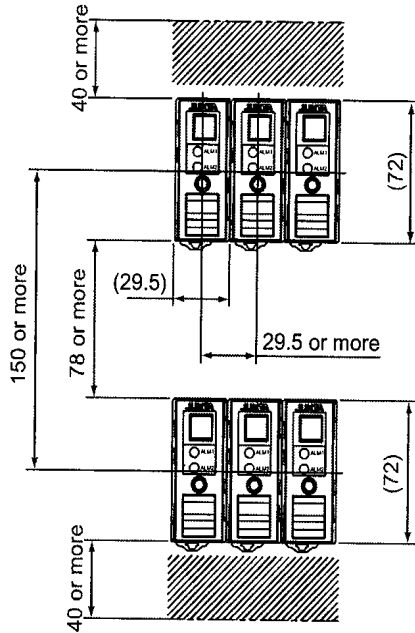

Wires are connected to the terminals of the isolator's socket. M3 screw terminals are provided for the connection of external signals. Attach a crimp-on lug to each wire for connection to the terminals.

- Recommended cables: A nominal cross-sectional area of 0.5 mm² or thicker for signal cables, and that of 1.25 mm² or thicker for power cables.
- For mounting, use M3 screws and crimp-on terminals with insulating sleeves appropriate for the wires used. Tool of the crimp-on terminals to be used should be appropriate for the crimp-on terminals.
- Mount a switch or 5A circuit breaker on the place near by the instrument, within operator's reach. And attach the indication that it is for disconnecting the instrument.

Input signal

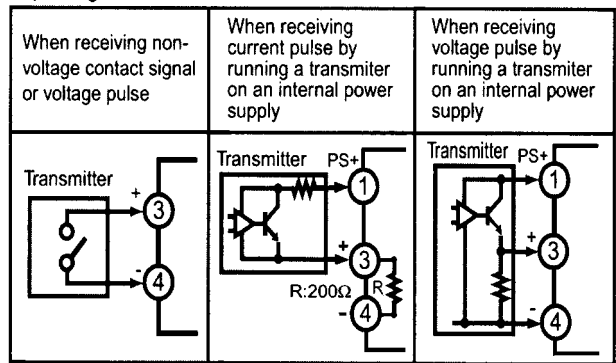

5. INSTALLATION LOCATION

- For installation, avoid any location where the product may be subject to vibrations, corrosive gases, or large amounts of dust, or where the product is exposed to water, oil, solvents, direct sunlight, radioactive rays, or strong electric or magnetic fields.
- If there is a possibility that lightning could induce a high surge voltage on the power and signal lines, provide lightning arresters on the line between the field instrument and indoor instrument in order to protect the product. Install a dedicated arrester on the field side and another on the indoor side.

6. EXTERNAL WIRING

WARNING

Turn OFF the power supply and make sure that none of the cables are not in the hot-line state before carrying out the wiring to avoid the possibility of electric shock.

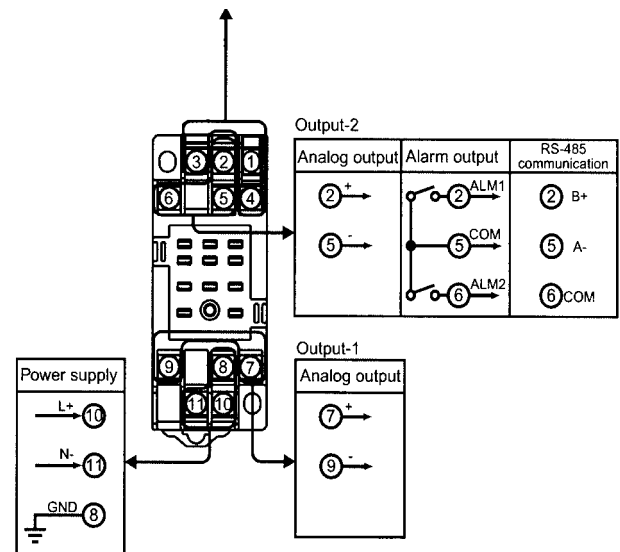

NOTE

- Keep all sources of noise away from the power and signal cables. Otherwise, accuracy cannot be assured.
- Provide grounding to a grounding resistance of 100Ω. The length of the grounding cable should be 20 m or less. Directly connect the lead from the ground terminal (terminal no. 8) of the isolator to the ground. Do not carry out daisy-chained inter-ground terminal wiring.

IMPORTANT

- If this instrument is used in a manner not specified in this manual, the protection provided by this instrument may be impaired.
- If the product is operated by a power supply exceeding the specifications, the product may become extremely hot and, as a result, damaged. To prevent this, ensure the following before turning on the power.
 - (a) The voltage of the supplied power and the input signal level meet the specifications of the product.
 - (b) External wires are connected to the correct terminals.
- Do not operate the product in the presence of flammable or explosive gases or vapors. To do is highly dangerous.
- The product is sensitive to static electricity; exercise care in operating it. Before you operate the product, touch a nearby metal part to discharge static electricity.

7. DESCRIPTION OF FRONT PANEL AND CONNECTION OF PC TERMINAL

7.1 Front Panel

The communications connector in the front panel is used for setting up parameters through the PC Terminal. The alarm-1 and alarm-2 LEDs light up if an alarm occurs.

7.2 Connecting the PC Terminal

Connect the signal conditioner module to the PC Terminal with connection cable.

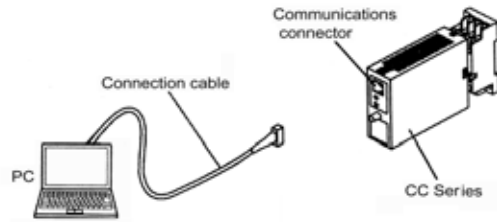
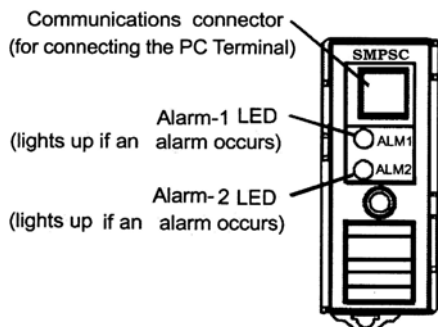

Connecting the PC Terminal

8. SETTING PARAMETERS

Set the parameters using the PC Setup Utility. Refer to the list of parameters in this manual and the Setup Utility.

8.1 Settings Related to Inputs and Outputs

8.1.1 Input Range Unit

When referring and setting the input range, select and set “Hz” or “KHz” in “Range Unit” item. Select “KHz” when input range is over 32000Hz.

8.1.2 Conversion Mode

Select and set the action of the instrument from “F/V CONVERTER” (F/V conversion) or “INTEGRATOR” (pulse integrator) in “Conversion mode” item.

- F/V converter: Set when converting 0 to 100% of frequency input to 0 to 100% of analog output, and outputting it.
- INTEGRATOR: Set when converting 0 to 100% of frequency in put to 0 to 100% of analog output after computing the average frequency from the pulse number integrated per sample time, and outputting it.

8.1.3 Sample Time

Select and set “AUTO” or “MANUAL” in “Sample Mode” item, when the conversion mode is set to “Pulse integration”.

- AUTO: Outputs the sample time forcibly on the provided conditions.
- MANUAL: sets the sample time within setting range.

8.1.4 Sample Mode

When the sample mode is set to “MANUAL”, set the sample time in numerical value in “Sample Time” item, Sample time setting range: 0.1 to 100 seconds, by 0.1 second. When the sample mode is set to “AUTO”, the sample time is forcibly decided on the following conditions.

0.1 second when F100 (100% input frequency) is 1KHz or more (1/F100)×100 seconds when F100 is over 1Hz and below 1KHz 100 seconds when F100 is 1Hz or less.

8.1.5 Input Range

Set the 0% value of input range to “Input low range”, and 100% of input range to “Input high range” within the numerically specified range.



NOTE

In case the input range is changed after factory-ship, the instrument may not work within the rated accuracy range depending on the changed input range. Perform the adjustment following the maintenance of this instruction manual after changing the input range.

8.1.6 Input Filter

When the chattering noise is generated in input, the input filter is used to restrain the influence. Select and set "ON" in "Input Filter" item, then the input filter for time constant of about 10ms will be connected.

8.1.7 Direction of Output Action

Analog output signals can be reversed. To reverse the signal from output-1, set "Direction of output-1 action" to REVERSE. To return the output-1 signal to normal, set "Direction of output-1 action" to DIRECT. For output-2, use the "Direction of output-2 action" item to set the active directions.

8.2 Settings Related to Communication Function

Set the following parameters when output-2 is specified for communication function. For more information on the communication function, see the Instruction Manual for CC Series Communication Function.

8.2.1 Communication Protocol

The communication protocol is MODBUS RTU Protocol.

8.2.2 Communication Address

Set the address number of the isolator numerically in a range of 1 to 255 in "Address" item.

8.2.3 Baud Rate

Set the baud rate by selecting from among 1200, 2400, 4800, 9600, and 19200 bps in "Baud rate" item.

8.2.4 Parity

Select and set NONE, EVEN, or ODD in "Parity" item.

8.2.5 Data Length

The data length is 8 bits.

8.2.6 Stop Bit

Select and set 1 bit or 2 bits in "Stop bit" item.

8.3 Settings Related to Alarm Output

Set the following parameters when output-2 is specified for alarm output.

8.3.1 Alarm Setpoints

Set the alarm setpoints of alarm-1 and alarm-2 in "Alarm-1 setpoint" item and "Alarm-2 setpoint" item numerically.

- Setting range: A range of 0% to 100% of input range
- Setting resolution: 0.1%

8.3.2 Direction of Alarm Action

Select the direction of alarm-1 action and that of alarm-2 action from among HIGH ALARM (high-limit alarm) and LOW ALARM (low-limit alarm) and set each in "Direction of alarm-1 action" item or "Direction of alarm-2 action" item.

- To activate alarm status when input signal \geq alarm setpoint, select HIGH ALARM.
- To activate alarm status when input signal \leq alarm setpoint, select LOW ALARM.

8.3.3 Hysteresis

Set alarm-1 and alarm-2 hysteresis, in "Alarm-1 hysteresis" item and "Alarm-2 hysteresis" item. Hysteresis is a value added to the alarm setpoint in order for an alarm status to be released (to normal) after the alarm status has been activated. The alarm status will be released in the following conditions, depending on the direction of alarm action.

- When HIGH ALARM (high-limit alarm) is set: Alarm is released when input signal $<$ (alarm setpoint - hysteresis).
- When LOW ALARM (low-limit alarm) is set: Alarm is released when input signal $>$ (alarm setpoint + hysteresis).
- Setting range: A range of 0% to 100% of input range
- Setting resolution: 0.1%

8.3.4 Alarm ON Delay and Alarm OFF Delay

Set alarm-1 and alarm-2 ON delays in "Alarm-1 ON delay setting" item and "Alarm-2 ON delay setting" item and then alarm-1 and alarm-2 OFF delays in "Alarm-1 OFF delay setting" item and "Alarm-2 OFF delay setting" item.

An alarm ON delay is a delay time from the establishment of alarm condition to alarm output; an alarm OFF delay is a delay time from the establishment of return-to-normal condition to output.

- Setting range: 0 to 999 seconds
- Setting resolution: 1 second

For example, when an alarm ON delay is set to 1 second, alarm output is generated if alarm status continues for more than 1 second after the input value exceeds the alarm setpoint. Further, when an alarm OFF delay is set to 2 seconds, alarm output is released if normal condition continues for more than 2 seconds after the input value has returned to normal from the alarm status.

8.3.5 Direction of Relay Action

Set the direction of relay energizing in alarm-1 normal condition and alarm-2 normal condition by selecting from among DEENERGIZED (de-energized under normal condition) and ENERGIZED (energized under normal condition) in "Normal direction of alarm-1 relay action" item and "Normal direction of alarm-2 relay action" item and set them.



9. DESCRIPTION OF ALARM ACTIONS

This section describes examples of alarm actions under the following conditions.

Item	Alarm-1 Setpoint	Alarm-2 Setpoint
Direction of alarm action	High-limit alarm	Low-limit alarm
Alarm setting	80%	15%
Hysteresis	10%	5%
Alarm ON delay	1sec.	3sec.
Alarm OFF delay	2sec.	4sec.
Description of alarm action	The alarm sounds if the condition where the input value is 80% or more of high-limit alarm continues for more than 1 second. After the alarm sounds, when the condition where input value is less than 70% of the high-limit alarm continues for more than 2 seconds, the status returns to normal.	The alarm sounds if the condition where the input value is 15% or less of low-limit alarm continues for more than 3 seconds. After the alarm sounds, when the condition where input value is less than 20% of the low-limit alarm continues for more than 4 seconds, the status returns to normal.

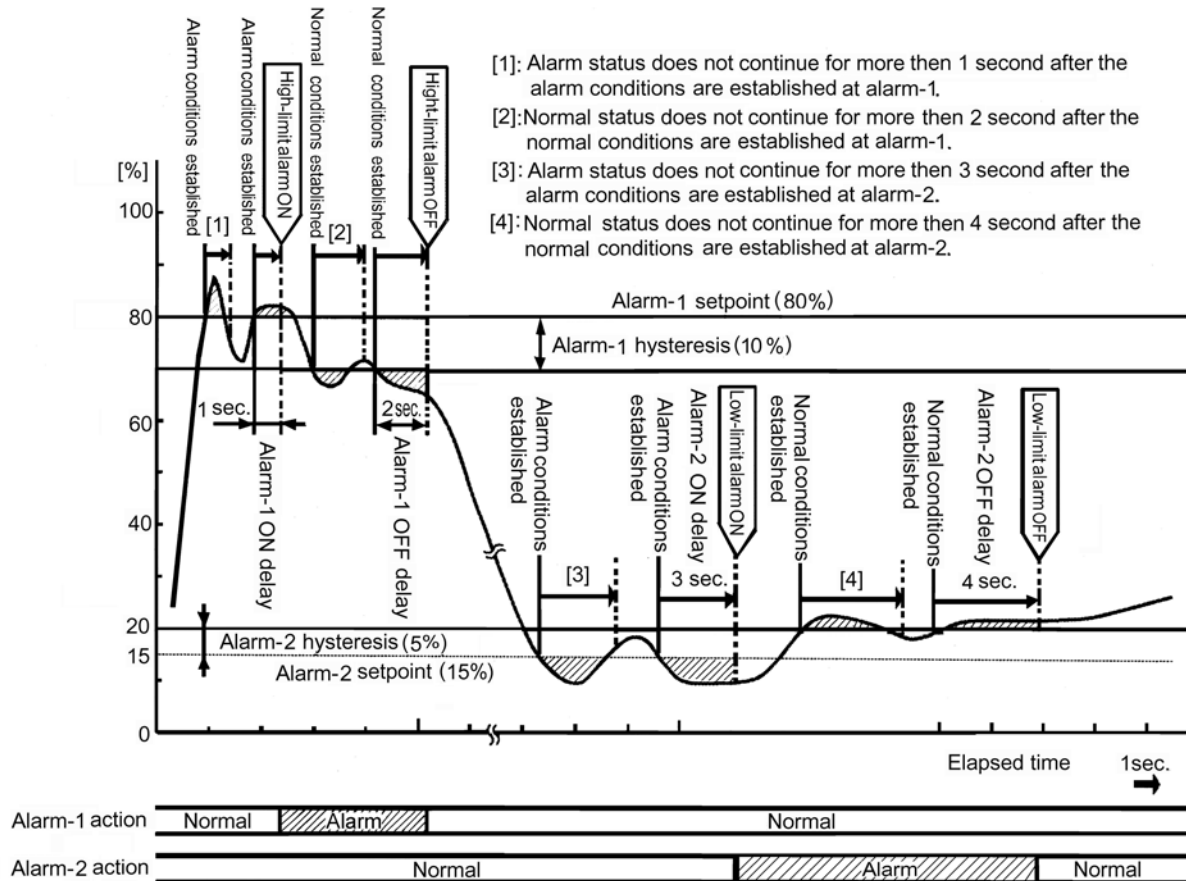

10. TIMING CHART OF PULSE INTEGRATION OPERATION

This timing chart shows an example of the integration operation where input frequency is 0 to 10Hz and sampling time is 2 sec.

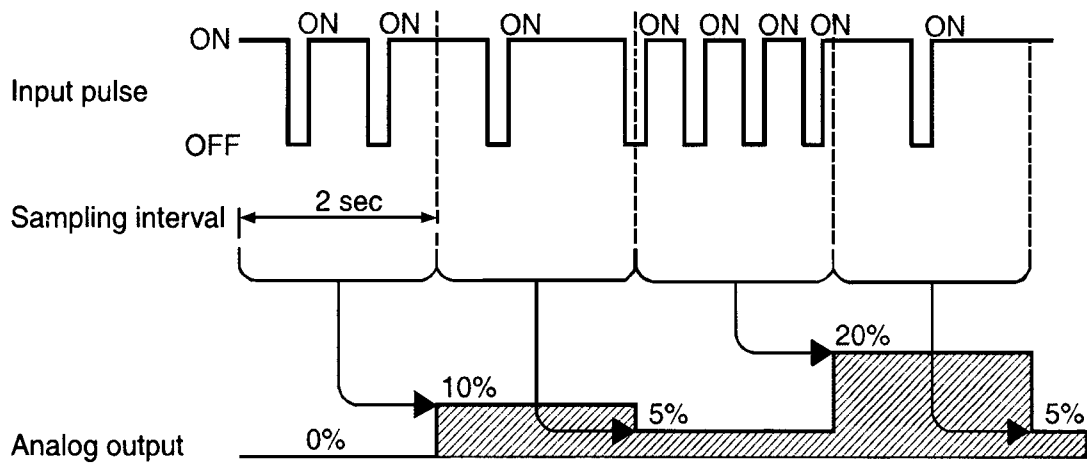

11. LIST OF PARAMETERS

Module Item				
Register Address	Name	Data Size (Byte)	Data Format	Description
0x0150	Model	8	String	"CCQ8"
0x0154	Tag no.	8	String	"ABC12345"
0x0158	Revise no.	2	Integer	Ver.×100
Display Item				
Register Address	Name	Data Size (Byte)	Data Format	Description
0x0160	Input value	4	Floating	Read the value of input
0x0162	Output value 1	4	Floating	Read the value of output-1
0x0164	Output value 2	4	Floating	Read the value of output-2
0x0166	Alarm-1 status	2	Integer	Read the status of alarm-1 (see Note 1)
0x0167	Alarm-2 status	2	Integer	Read the status of alarm-2 (see Note 1)
0x0168	Status	2	Integer	Read the status of module (see Note 2)

Note 1: Alarm Status

b15	b14	b13	b12	b11	b10	b9	b8	b7	b6	b5	b4	b3	b2	b1	b0
0	0	0	0	0	0	0	0	0	0	RA	DoFF	DoN	Hys	Dir	Act

Relay Action
0: De-energized
1: Energized

Alarm-off Delay
0: No Delay
1: Delay On

Alarm-on Delay
0: No Delay
1: Delay On

Alarm Active
0: Inactive
1: Active

Direction
0: Low Alarm
1: High Alarm

Hysteresis
0: No Hysteresis
1: Hysteresis On



Note 2: Status

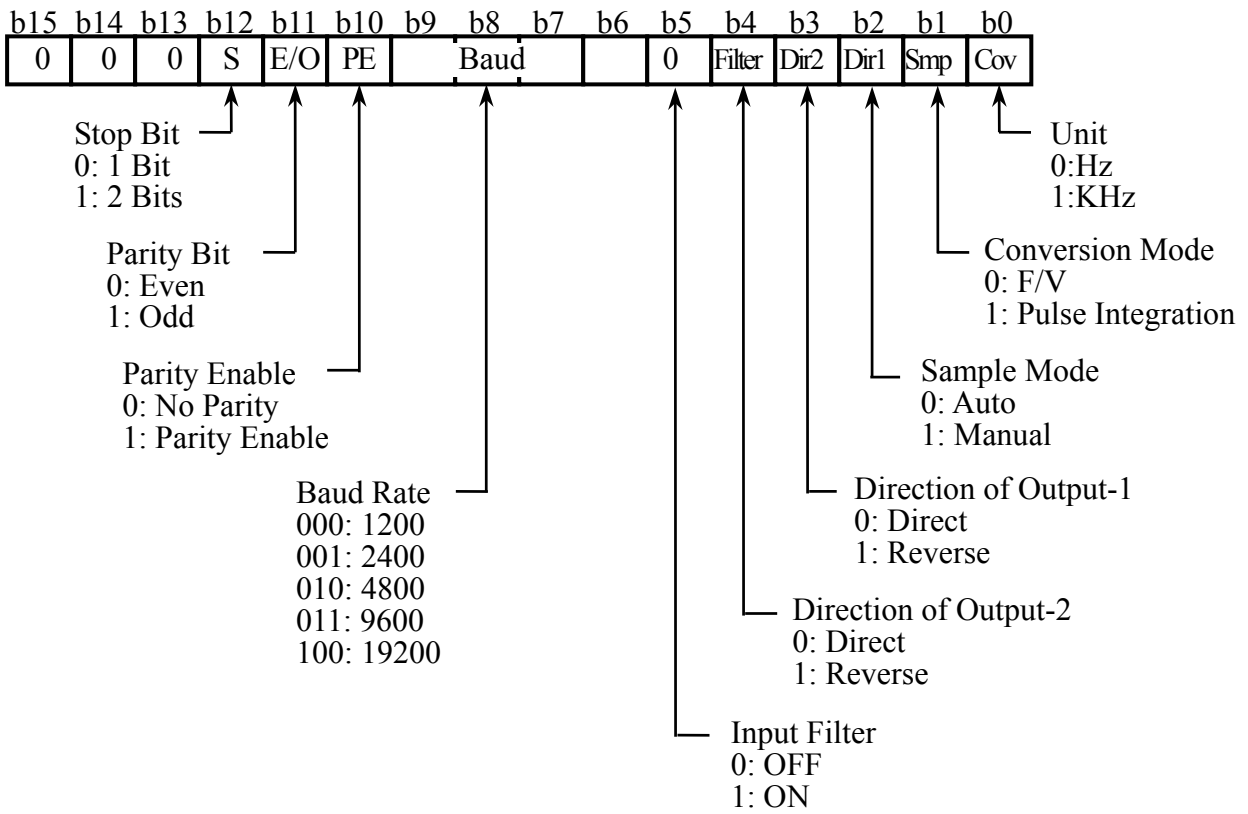

Setting Item				
I/O Setting				
Register Address	Name	Data Size (Byte)	Data Format	Description
0x0020	Tag no. 1	8	String	“ASCII543“
0x0024	Tag no. 2	8	String	“ASCII543“
0x0028	Comment 1	8	String	“ASCII543“
0x002C	Comment 2	8	String	“ASCII543“
0x0030	Conversion mode	2	Integer	0:F/V conversion, 1:Pulse integration
0x0031	Range Unit	2	Integer	0:Hz, 1:KHz
0x0032	Input low range	4	Floating	Set the 0% value of input range (0Hz)
0x0034	Input high range	4	Floating	Set the 100% value of input range (10Hz)
0x0036	Direction of output-1 action	2	Integer	0:Direct, 1:Reverse
0x0037	Direction of output-2 action	2	Integer	0:Direct, 1:Reverse
0x0038	Sample Mode	2	Integer	0:Auto, 1:Manual
0x0039	Sample Time	2	Integer	0.1-100.0 secondsx10
0x003A	Low input cut point	2	Integer	0.0-100.0%x10
0x003B	Input Filter	2	Integer	0:OFF, 1:ON
Alarm Output Setting				
Register Address	Name	Data Size (Byte)	Data Format	Description
0x0040	Alarm-1 setpoint	2	Integer	[0.0-100.0%]x10
0x0041	Alarm-2 setpoint	2	Integer	[0.0-100.0%]x10
0x0042	Direction of alarm-1 action	2	Integer	0:Low alarm, 1:High alarm
0x0043	Direction of alarm-2 action	2	Integer	0:Low alarm, 1:High alarm
0x0044	Alarm-1 hysteresis	2	Integer	[0.0-100.0%]x10
0x0045	Alarm-2 hysteresis	2	Integer	[0.0-100.0%]x10
0x0046	Alarm-1 ON delay setting	2	Integer	0 to 999 seconds
0x0047	Alarm-2 ON delay setting	2	Integer	0 to 999 seconds
0x0048	Alarm-1 OFF delay setting	2	Integer	0 to 999 seconds
0x0049	Alarm-2 OFF delay setting	2	Integer	0 to 999 seconds
0x004A	Normal direction of alarm-1 relay action	2	Integer	0:De-energized, 1:Energized
0x004B	Normal direction of alarm-2 relay action	2	Integer	0:De-energized, 1:Energized
Communication Setting				
Register Address	Name	Data Size (Byte)	Data Format	Description
0x0050	Communication protocol	2	Integer	Modbus RTU protocol
0x0051	Address	2	Integer	1 to 255
0x0052	Baud rate	2	Integer	1200/2400/4800/9600/19200 bps
0x0053	Parity	2	Integer	0:None, 1:Odd, 2:Even
0x0054	Data length	2	Integer	8 bits
0x0055	Stop bit	2	Integer	1 bit or 2 bits
Adjusting Item				
Register Address	Name	Data Size (Byte)	Data Format	Description
0x0062	0% scale adjustment of output-1	2	Integer	Set the 0% output value (0x9556)
0x0063	100% scale adjustment of output-1	2	Integer	Set the 100% output value (0x6AAA)
0x0064	0% scale adjustment of output-2	2	Integer	Set the 0% output value (0x9556)
0x0065	100% scale adjustment of output-2	2	Integer	Set the 100% output value (0x6AAA)
Test Item				
Register Address	Name	Data Size (Byte)	Data Format	Description
0x0071	Forced output 1	2	Integer	0:OFF, 1:ON
0x0072	Forced output 2	2	Integer	0:OFF, 1:ON
0x0073	Forced alarm-1 output	2	Integer	0:OFF, 1:ON
0x0074	Forced alarm-2 output	2	Integer	0:OFF, 1:ON



11. MAINTENANCE

The product starts running immediately when the power is turned on; however, it needs 10 to 15 minutes of warm-up before it meets the specified performance. For cleaning the instrument, use a soft and dry cloth.

11.1 Calibration apparatus

- A pulse generator
- A voltmeter
- A counter
- A precision resistor of $250\ \Omega \pm 0.01\%$, 1W (for current output)

11.2 Calibration Procedure

Connect the instruments as shown in figure below. First adjust the output-1 signal and then the output-2 signal. Produce input signal equivalent to 0, 25, 50, 75, and 100% of the input span from the voltage and current generator to the isolator. Then, check that the isolator's output signal shows voltage corresponding to 0, 25, 50, 75, and 100% of the input span within the rated accuracy range.

