

General Specifications

Model CCH1 Isolator (Isolated Single-output and Isolated Dual-output Types)

SMPSC

General

The CCH1 is a compact, plug-in type isolator that converts DC current or DC voltage signals into isolated DC current or DC voltage signals.

Model and Suffix Codes

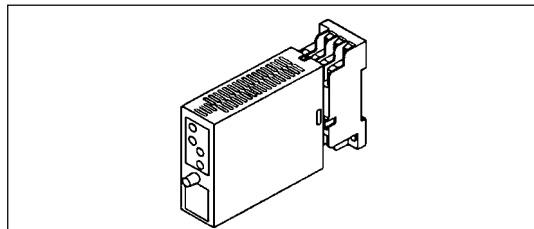
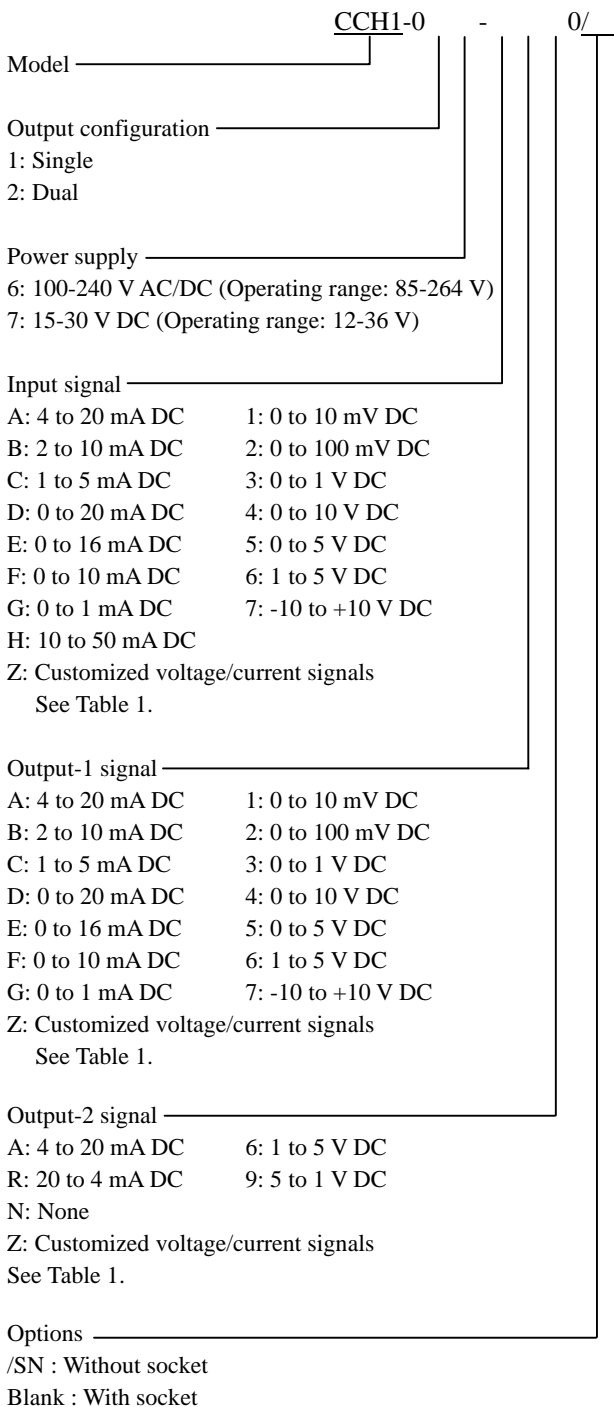

Input/Output Specifications

Input signal: DC voltage or DC current signal.

Input Range	Input Resistance	Input Range	Input Resistance
4 to 20 mA DC	250	0 to 10 mV DC	1M during power on
2 to 10 mA DC	500	0 to 100 mV DC	10K during power off
1 to 5 mA DC	1K	0 to 1 V DC	
0 to 20 mA DC	250	0 to 10 V DC	1M during power on
0 to 16 mA DC	250	0 to 5 V DC	800K during power off
0 to 10 mA DC	500	1 to 5 V DC	
0 to 1 mA DC	1K	-10 to +10 V DC	
10 to 50 mA DC	100		

Allowable input level:

- Voltage input: Within $\pm 30V$ DC
- Current input: Any level that satisfies the following condition, $(\text{input current})^2 \times \text{input resistance} \leq 0.5W$

Output signal: DC voltage or DC current signal

Allowable load resistance:

Output-1 Range	Allowable Load Resistance	Output-1 Range	Allowable Load Resistance
4 to 20 mA DC	750 max.	0 to 10 mV DC	250K min.
2 to 10 mA DC	1500 max.	0 to 100 mVDC	250K min.
1 to 5 mA DC	3000 max.	0 to 1 V DC	2K min.
0 to 20 mA DC	750 max.	0 to 10 V DC	10K min.
0 to 16 mA DC	900 max.	0 to 5 V DC	2K min.
0 to 10 mA DC	1500 max.	1 to 5 V DC	2K min.
0 to 1 mA DC	15K max.	-10 to +10V DC	10K min.
Output-2 Range	Allowable Load Resistance	Output-2 Range	Allowable Load Resistance
4 to 20 mA DC	350 max.	1 to 5 V DC	2K min.
20 to 4 mA DC	350 max.	5 to 1 V DC	2K min.

Zero adjustment: -5 to +5%

Span adjustment: 95 to 105%



Standard Performance

Accuracy rating: $\pm 0.1\%$ of span (aside from the $\pm 0.1\%$ accuracy of the external resistor for current input); accuracy is not guaranteed for output levels less than 0.5% of the span of a 0 to X mA output range type.

Response speed: 30ms, 63% response (10 to 90%)

Effects of power line regulation: Up to $\pm 0.1\%$ of span for the regulation within allowable range of each supply voltage range.

Effects of ambient temperature variations: Up to $\pm 0.15\%$ of span per 10

Conformance to EMC Standards

Applicable EMC standard: EN61326

CE-certified models mean those which are CE certified on condition that they be operated over a supply voltage range of 15~30 V DC ($\pm 20\%$) only.

Power Supply and Isolation

Supply rated voltage range: 100-240 V AC/DC 50/60Hz or 15-30 V DC

Supply input voltage range: 100-240 V AC/DC (-15, +10%) 50/60Hz or 15-30 V DC ($\pm 20\%$)

Power consumption: 2.2W at 24V DC; 2.1W at 110 V DC; 4.2 VA at 100V AC; 6.1VA at 200 V AC

Insulation resistance: 100 M Ω minimum at 500V DC between input, output-1,output-2,power supply and grounding terminals mutually

Withstanding voltage: 2000 V AC for one minute between input, (output-1 and output-2), power supply and grounding terminals mutually; 1000 V AC for one minute between output-1 and output-2 terminals

Environmental Conditions

Operating temperature range: 0 to 50

Operating humidity range: 5 to 90% RH (no condensation)

Operating conditions: Avoid installation in such environments as corrosive gas like sulfide hydrogen, dust, sea breeze and direct sunlight.

Installation altitude: 2000 m or less above sea level.

Mounting and Appearance

Material: Modified polyphenylene oxide (casing)

Mounting method: Wall or DIN rail mounting

Connection method: M3 screw terminals

External dimensions: 76(H) \times 29.5(W) \times 124.5(D) mm (including a socket)

Weight: Approx. 116g (main unit), approx. 51g (socket)

Customized Signal Specifications

Table 1. Manufacturable Ranges

	Current Signal	Voltage Signal
Input range (DC)	0 to 150 mA	-300 to +300 V
Span (DC)	100 μ A to 150mA	10 mV to 600 V
Zero elevation	0 to 73 %	-80 to +73 %
Output range (DC)	0 to 24 mA	-10 to +10 V
Span (DC)	1 to 24 mA	10mV to 20V
Zero elevation	0 to 200 %	-100 to +200 %



Terminal Assignments

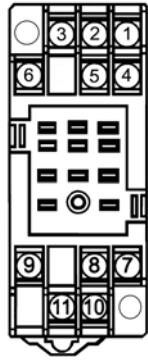

1	INPUT	(+)
2	OUTPUT-2	(+)
3	INPUT	(-)
4	N.C.	
5	OUTPUT-2	(-)
6	N.C.	
7	OUTPUT-1	(+)
8	GND	
9	OUTPUT-1	(-)
10	SUPPLY	(L+)
11	SUPPLY	(N-)

Note: For single-output type, OUTPUT2 is N.C.

Block Diagram

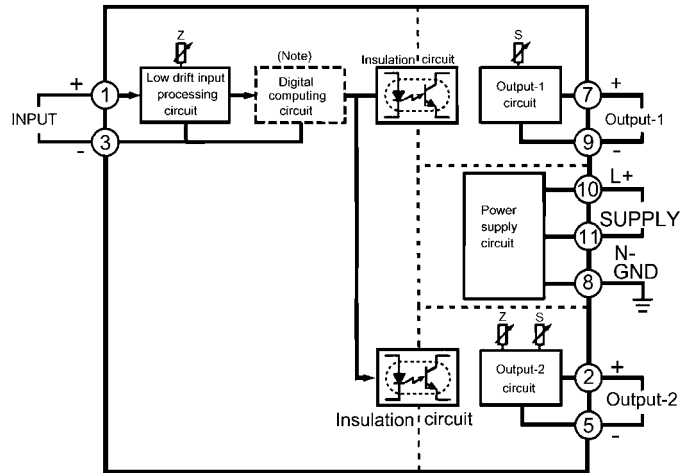

Note: Digital computing circuit is added for the input/output suffix codes other than "A" and "6"

External Dimensions

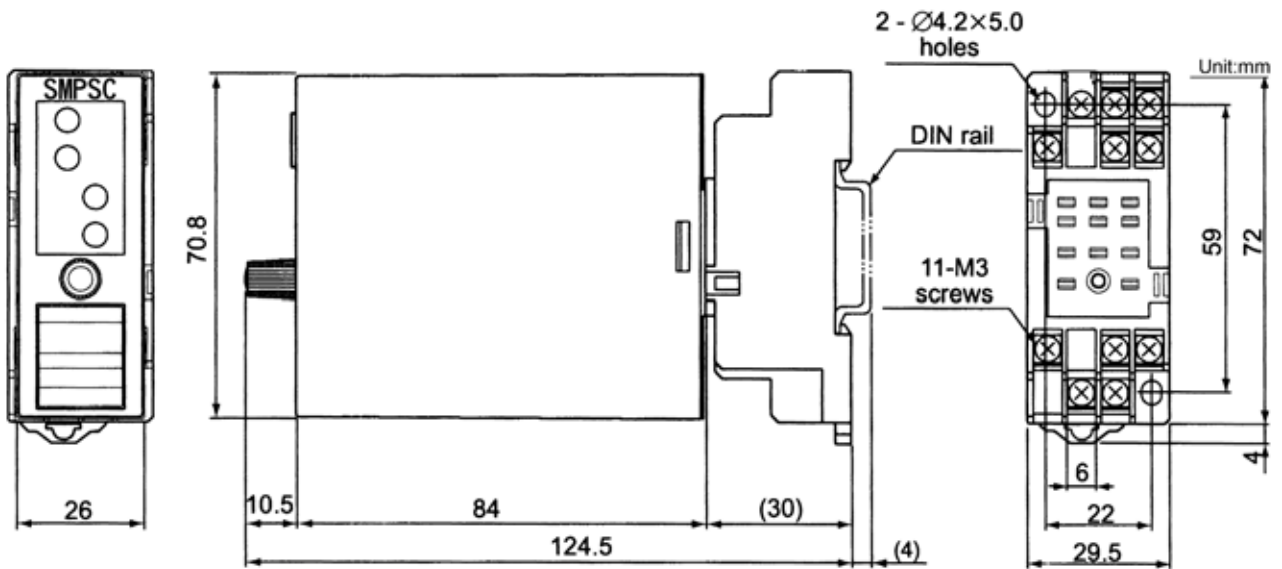

The information covered in this document is subject change without notice for reasons of improvements in quality and/or performance.

