

1. PRECAUTION

For the correct use of this product, read through this manual before use. Please keep this manual carefully after use. This instrument has been thoroughly tested at the factory before shipment. When you receive it, visually inspect it for damage and check the accessories.

2. CHECKING PRODUCT SPECIFICATIONS AND THE CONTENTS OF PACKING

(1) Model Number and Specification Check

Check that the model number and specifications shown on the nameplate attached on the side of the product are as ordered.

(2) Contents of the Packing

Check that packing contains the following items:

- CCG1 main unit × 1
- Instruction Manual × 1

3. GENERAL

This compact plug-in type PT Transmitter converts AC current signal (PT output, etc) into isolated DC voltage or DC current signal.

4. MOUNTING METHODS

4.1 Wall Mounting

Loosen the main unit-fixing screw isolator to disconnect the main unit from the socket. Next, anchor the socket onto the wall with screws. Then, plug the main unit into the socket and secure the main unit with the main unit-fixing screw.

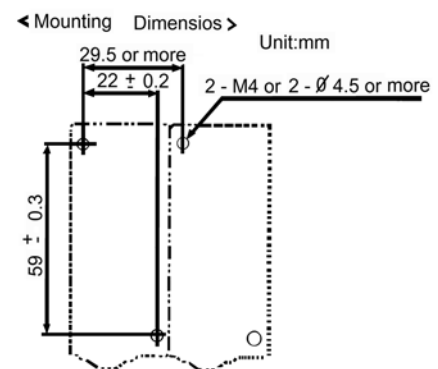
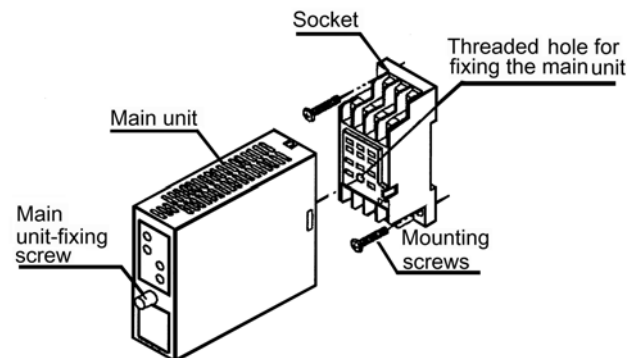

4.2 DIN Rail Mounting

Locate the isolator so that DIN rail fits into the upper part of the DIN-rail groove at the rear of the socket, and fasten the socket using the slide lock at lower part of the socket.

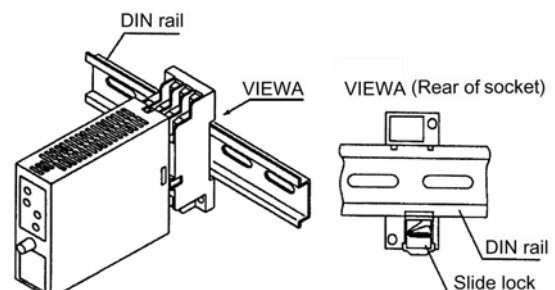

4.3 In Case of Top-Bottom Close Mounting

Transmitter should be mounted horizontally with its top and bottom slits being vertical. The top and bottom slits should not be covered. The area for wiring is required above and below the transmitter (the area with slant lines).

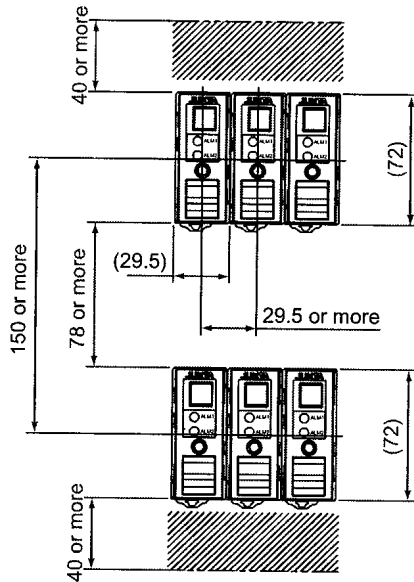

5. INSTALLATION LOCATION

- For installation, avoid any location where the product may be subject to vibrations, corrosive gases, or large amounts of dust, or where the product is exposed to water, oil, solvents, direct sunlight, radioactive rays, or strong electric or magnetic fields.
- If there is a possibility that lightning could induce a high surge voltage on the power and signal lines, provide lightning arresters on the line between the field instrument and indoor instrument in order to protect the product. Install a dedicated arrester on the field side and another on the indoor side.

6. EXTERNAL WIRING

WARNING

Turn OFF the power supply and make sure that none of the cables are not in the hot-line state before carrying out the wiring to avoid the possibility of electric shock.

Wires are connected to the terminals of the isolator's socket. M3 screw terminals are provided for the connection of external signals. Attach a crimp-on lug to each wire for connection to the terminals.

- Recommended cables: A nominal cross-sectional area of 0.5 mm^2 or thicker for signal cables, and that of 1.25 mm^2 or thicker for power cables.
- For mounting, use M3 screws and crimp-on terminals with insulating sleeves appropriate for the wires used. Tool of the crimp-on terminals to be used should be appropriate for the crimp-on terminals.

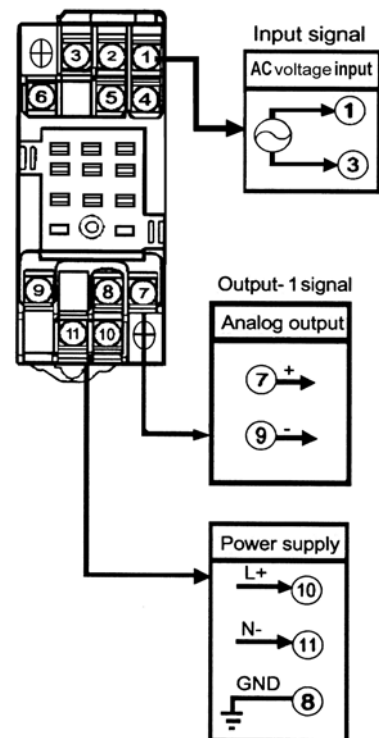

NOTE

- Keep all sources of noise away from the power and signal cables. Otherwise, accuracy cannot be assured.
- Provide grounding to a grounding resistance of 100 Ω. The length of the grounding cable should be 20 m or less. Directly connect the lead from the ground terminal (terminal no. 8) of the isolator to the ground. Do not carry out daisy-chained inter-ground terminal wiring.

IMPORTANT

- If this instrument is used in a manner not specified in this manual, the protection provided by this instrument may be impaired.
- If the product is operated by a power supply exceeding the specifications, the product may become extremely hot and, as a result, damaged. To prevent this, ensure the following before turning on the power.
 - (a) The voltage of the supplied power and the input signal level meet the specifications of the product.
 - (b) External wires are connected to the correct terminals.
- Do not operate the product in the presence of flammable or explosive gases or vapors. To do is highly dangerous.
- The product is sensitive to static electricity; exercise care in operating it. Before you operate the product, touch a nearby metal part to discharge static electricity.

7. MAINTENANCE

The product starts running immediately when the power is turned on; however, it needs 10 to 15 minutes of warm-up before it meets the specified performance. For cleaning the instrument, use a soft and dry cloth.

7.1 Calibration apparatus

- A voltage and current generator
- A voltmeter
- A precision resistor of 250 Ω ±0.01%, 1W (for current output)

7.2 Calibration Procedure

Connect the instruments as shown in figure below. First adjust the output-1 signal and then the output-2 signal.

Produce input signal equivalent to 0, 25, 50, 75, and 100% of the input span from the voltage and current generator to the isolator. Then, check that the isolator's output signal shows voltage corresponding to 0, 25, 50, 75, and 100% of the input span within the rated accuracy range.

